

PART NUMBER : SFSE ASSY

REVISION LEVEL :

Amendment	Date	By

Tolerances Unless Specified
 Decimal Places 0 +/- 0.5
 0.0 +/- 0.1
 0.00 +/- 0.05

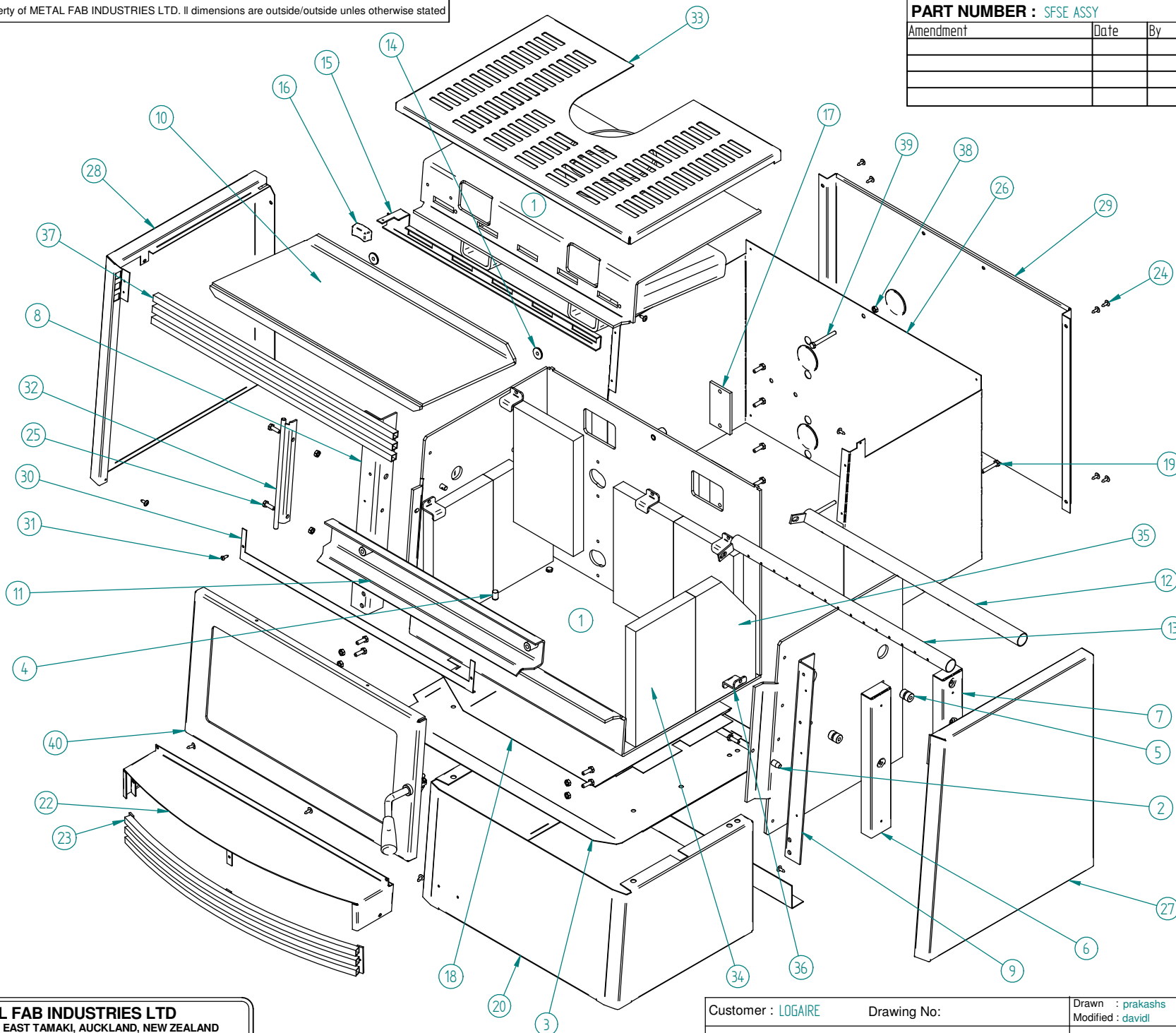

Weight = 0.000 kg

METAL FAB INDUSTRIES LTD
 38 HARRIS ROAD, EAST TAMAKI, AUCKLAND, NEW ZEALAND
 Ph 09 274 8265, Fax 09 274 8472, Email : engdept@metalfab.co.nz

Customer : LOGAIRE	Drawing No :	Drawn : prakash	Date : 22/11/2005	Chk'd By :
Part Name : SFSE FULL ASSEMBLY	Material :	Modified : david	Date : 16/02/2006	Finish : Natural

PART NUMBER : SFSE ASSY

REVISION LEVEL :

Amendment	Date	By

Tolerances Unless Specified
 Decimal Places 0 +/- 0.5
 0.0 +/- 0.1
 0.00 +/- 0.05

Item Number	Document Number	Title	Material	Quantity
1*	SFSEAC004	SFSE FIREBOX ASSEMBLY		1
2	MIC00079	LOGAIRE CATCH PIN	FCMS 10mm DIA	1
3*	SFS00176	SFS BASE HEAT SHIELD	Zintec 1.0 mm	1
4*	MET00075	MET BRICK RETAINER PIN	10MM BMS FREE MACHINING	6
5	HBA00129	HBA AIR DEFLECTOR SPACER	16MM BMS FREE MACHINING	4
6*	MIC00123	MIC SEC AIR CHANNEL	Cold Rolled 1.2mm	2
7	HCA00164	HCA SEC AIR CHANNEL	Cold Rolled 1.2mm	2
8*	SFSE00183	SFSE DOOR RIDDLE STIFFNER L/H	Cold Rolled 3.0mm	1
9*	SFSE00184	SFSE DOOR RIDDLE R/H	Cold Rolled 3.0mm	1
10*	SFSEAC109	SFSE BAFFLE ASSEMBLY		1
11*	SFSEAC102	SFSE AIR DEFLECTOR ASSEMBLY		1
12*	SFSEAC136	SFSE REAR AIR BAR ASSEMBLY		1
13*	SFSEAC138	SFSE FRONT AIR BAR ASSEMBLY		1
14*	MIC00083	LOGAIRE METRO AIR SLIDE SPACER	7/8" BMS FREE MACHINING	2
15*	SFSE00036	SFSE AIR SLIDE	Cold Roll 2.0mm	1
16	MIC00375	MIC AIR SLIDE HANDLE	PLASTIC	1
17*	SFSE00135	CSFE WET BACK COVER	Hot Rolled 5.0mm	2
18*	SFS00175	SFS PED HEAT SHIELD	Zintec 1.0 mm	1
19	F-M6X35-HB-SC-ZP	BOLT M6 x 35 ZP	Purchased	8
20*	SFSAC020	SFS PEDASTAL ASSY		1
21*	F-M6-RN-TS	M6 RIVNUT	Purchased	4
22*	SFSAC011	SFS ASH LIP ASSY		1
23	SFSAC201	SFS LOWER GRILL COMPLETE		1
24	F-8GX1.2-S-MS-PO-BLK	8G X 1/2 SCREW MUSH POZI BLK	Purchased	15
25	F-M6X20-HB-SC-ZP	BOLT M6 X 20 ZINC PLATED	Purchased	11
26*	SFSE00038	SFSE HEAT SHIELD WRAP	Zintec 1.20 mm	1
27*	SFSE00007	SFSE R/H SIDE PANEL	Enamel 1.2 mm	1
28*	SFSE00006	SFSE L/H SIDE PANEL	Enamel 1.2 mm	1

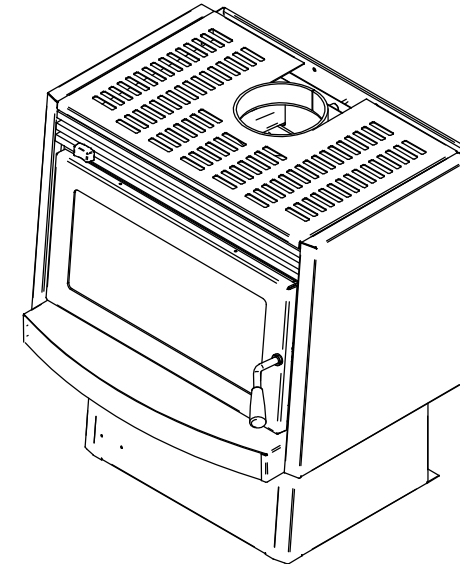

Item Number	Document Number	Title	Material	Quantity
29*	SAF00012	SAF BACK PANEL	Zintec 1.2 mm	1
30*	SFSE00016	SFSE AIR SLIDE COVER	Zintec 1.2 mm	1
31	F-8GX1.2-MS-PA-PO-BLK	8G X 1/2" PAH HEAD POZI SCREW BLK	Purchased	1
32*	MICAC190	MIC DOOR HINGE ASSEMBLY		1
33*	SAF00003	SAF TOP GRILL	Enamel 1.6 mm	1
34*	MIC00354	MIC BRICK	MASONRY	5
35*	MCA00354	MCA ANGLE BRICK	MASONRY	2
36	HBA00118	HBA BRICK RETAINER	Hot Roll 3.0mm	5
37	SFSE00017	SFSE STRAIGHT LOUVRE	Stainless steel	3
38	F-M6-HN-ZP	HEX NUT M6 ZP	Purchased	8
39*	FSBOLTM6X35ZP	bolts m6 x 35 zinc plated	Purchased	2
40	PYRAC730	PYRROS DOOR ASSEMBLY		1

Weight = 0.000 kg

METAL FAB INDUSTRIES LTD
 38 HARRIS ROAD, EAST TAMAKI, AUCKLAND, NEW ZEALAND
 Ph 09 274 8265, Fax 09 274 8472, Email : engdept@metalfab.co.nz

Customer : LOGAIRE	Drawing No:	Drawn : prakashs	Date : 22/11/2005	Chk'd By :
		Modified : david	Date : 16/02/2006	
Part Name : SFSE FULL ASSEMBLY		Material :	Finish : Natural	